

# Wheel Balancing Instructions

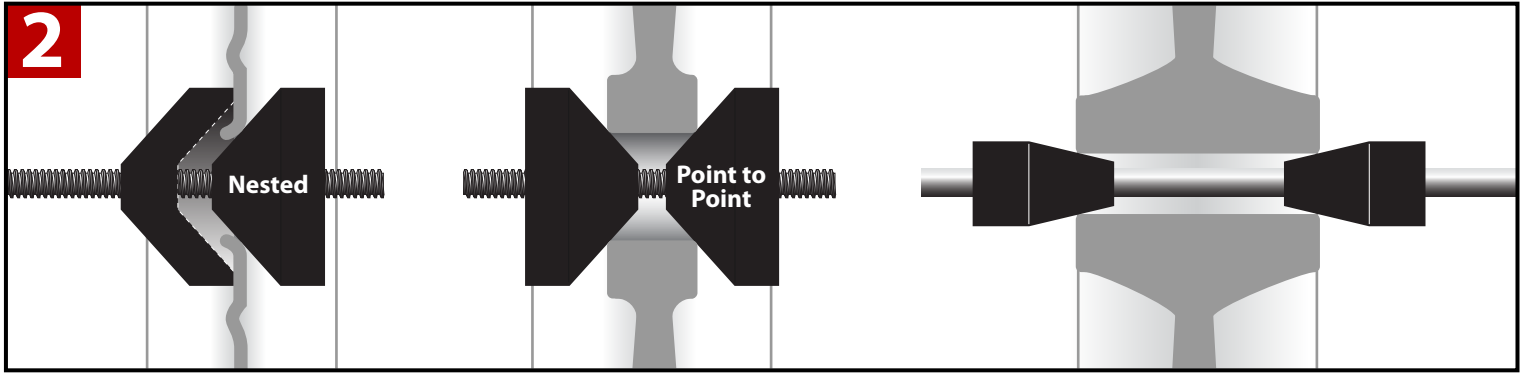

**1** - Remove the existing weights from the wheel and note the total weight.  
 • Remove Sprocket Carrier with cush drives and/or spacers if installed.  
 • Rotors stay attached.

**2** Mount your wheel on the balancer with the appropriate rod and cone set.

**3** Lightly touch the wheel (**DO NOT SPIN**) to cause slight motion. **Gravity will cause the heavy spot in the wheel to rotate to the bottom.**

4 - Clean top portion of wheel to allow adhesion of weights. Always begin with the amount of weight equal to what was removed when you started.

**5** Temporarily, apply weight to the TOP of the wheel (which is the 'light' spot), by peeling back only a small portion of the adhesive covering on the weight. This will allow the weight to stick enough for testing and still be easily removed.

**6** Rotate the wheel approximately 45 degrees.

--> If the weight rotates DOWN = Reduce the amount of weight and repeat step 6

--> If the weight rotates UP = add more weight and repeat step 6

Continue this process until you can rotate the wheel to any position and it does not rotate on its own. This indicates the wheel is now balanced and you can proceed to step 7

**7** When the wheel does not rotate on its own, you have the right amount of weight. Permanently apply the weights by removing all paper covering the adhesive on the weights and apply with moderate pressure. Optionally, you may want to mark the position of those weights on the rim with a piece of tape, so you are sure to replace them in exactly the same position.

