

Deluxe Arm Kit

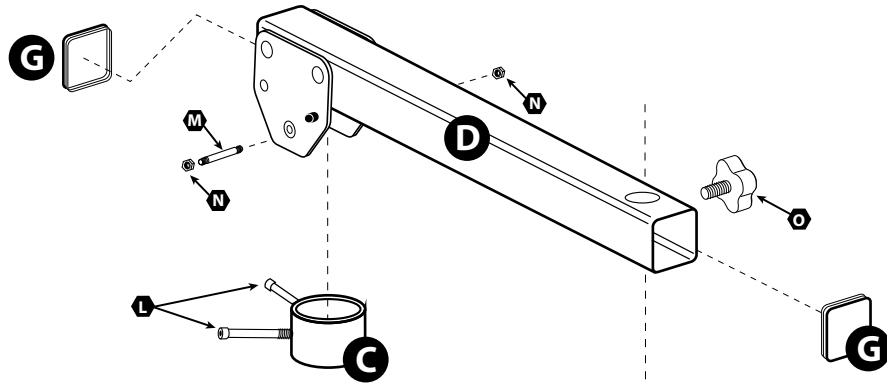

Machine Parts

- A** Rear Frame Arm
- B** Back Post
- C** Spoon Bar Collar
- D** Upper Arm
- E** Center Post Plug
- F** Center Pin
- G** End Cap (2)

Assembly Parts

- K** 5/16" x 5/16" Set Screw (4)
- L** 5/16" x 3" Socket Head Bolt (2)
- M** 5/16" x 3" Stud
- N** 5/16" Nylock Nut (2)
- O** Small Knob

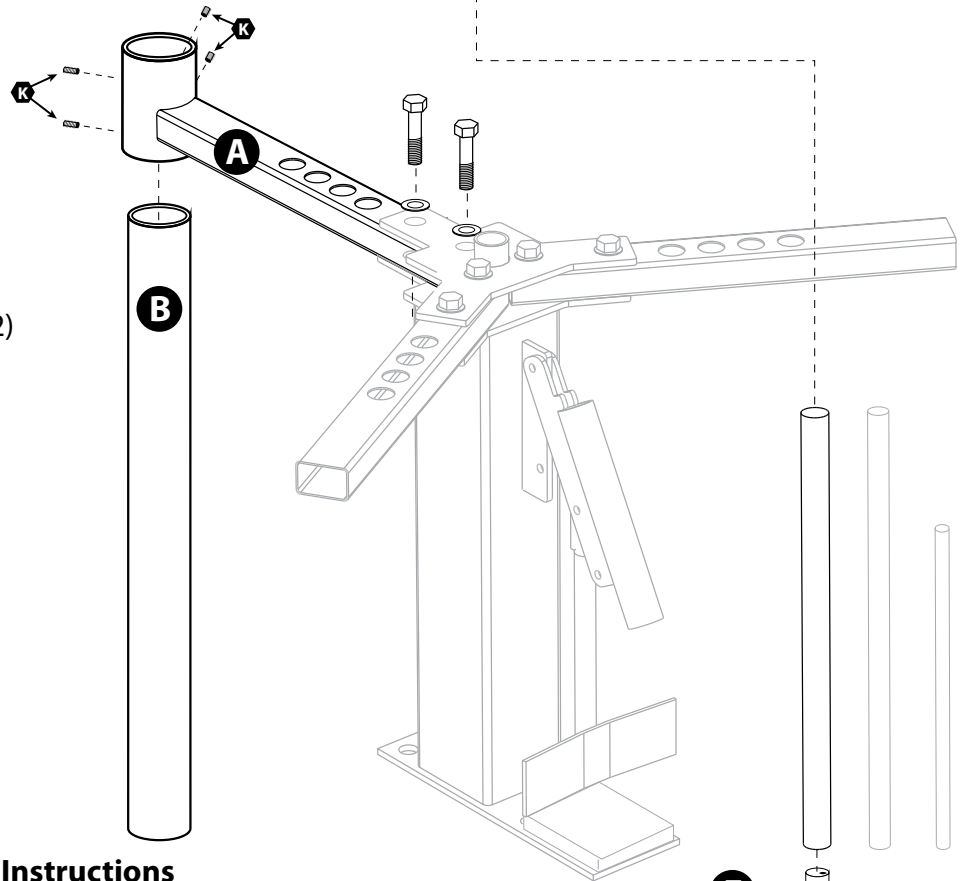

Cycle Hill Deluxe Arm Assembly Instructions

Note: Cycle Hill tire changer is already assembled and ready for use.

Center Post Modification:

STEP 1 Place one end of your existing 1" center post on a block of wood, or suitable surface,

STEP 2 Tap the End Cap into place with a hammer

STEP 3 Tap the End Pin into the hole in the End Cap with a hammer.

Upper Arm Installation:

STEP 1 Remove two bolts securing the rear frame arm

STEP 2 Attach new Rear Frame Arm (A) to the Machine Stand Assembly, re-using the original bolts and washers.

STEP 3 Slide Back Post (B) into the rear Frame Arm (A). Attach with 4 set screws (K).

STEP 4 Secure one Spoon Bar Collar (C) onto the Back Post approximately 18" above Frame Arm by tightening 2 screws (L).¹

STEP 5 Position the Upper Arm (D) over the Back Post as shown. Slide one double ended stud (M) through the hole in the rear tab and secure on each end with Nyloc nuts (N). Do not overtighten. The upper arm will swing up and down freely, when released.

STEP 6 Insert the Center Post into the hole on the end of the Upper Arm. Hold in position using the Small Knob (O) on the side. Adjust the Center post height according to the wheel and tire combination you are changing. See website for complete tire changing instructions.

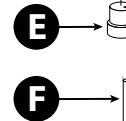

¹Pre-installed **Parts, labels, names, drawings, pricing and availability are subject to change without notice. See website for most current information.